

* OIL TANK HOLD DOWN INCREASES THESE DIMENSIONS BY 1 INCH

* FROM TOP OF TRANSOM TO TOP OF ENGINE WHEN TILTED UP.

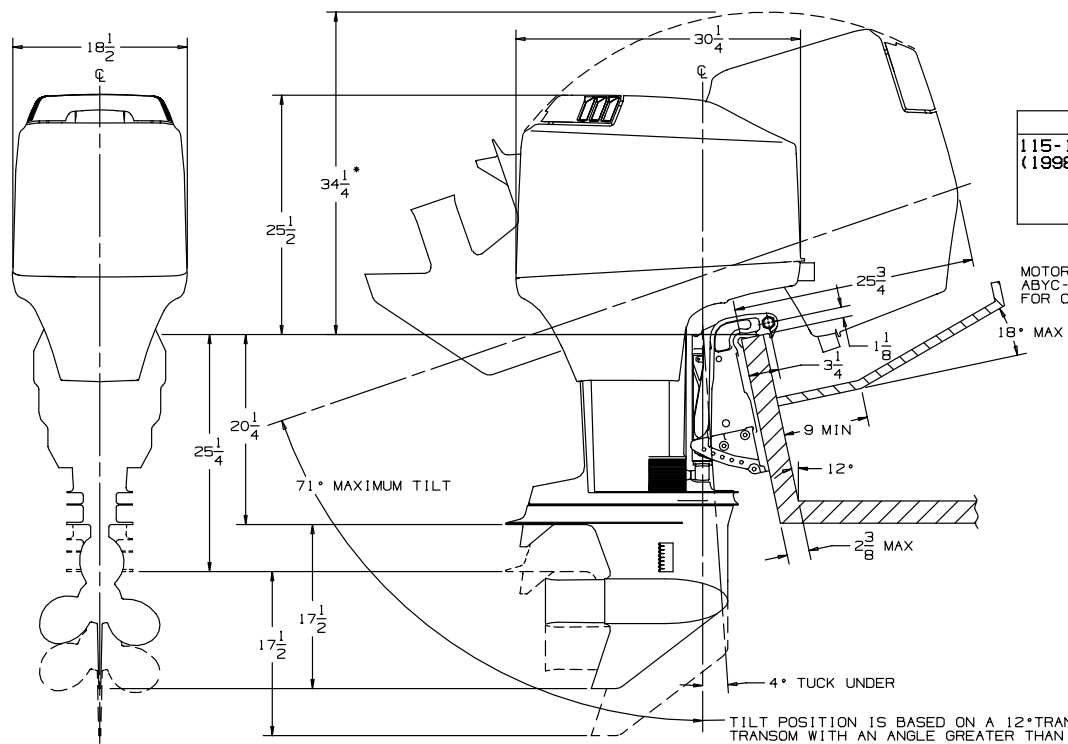

MODEL
115-135-150 OPTIMAX
(1998 M.Y. & NEWER)

MOTOR WELL: SEE ABYC-S-12 STANDARD FOR OTHER DIMENSIONS

TILT POSITION IS BASED ON A 12° TRANSOM ANGLE. A TRANSOM WITH AN ANGLE GREATER THAN 12° WILL REDUCE THE MAXIMUM TILT ANGLE AND INCREASE TUCK UNDER ANGLE.

LET.	DRAWING RELEASE OR BRIEF DESCRIPTION OF CHANGE	BY	DATE	E.C.N. NO.
—	DRAWING RELEASE	BCK	02-20-97	00492
A	ADDED: 115 MODEL; MODEL YEAR CALLOUT; RIGGING TUBE SNOOT REM: 175 MODEL	T P G	02 16 99	0311

COMPUTERIZED DOCUMENT
NO MANUAL REVISIONS PERMITTED

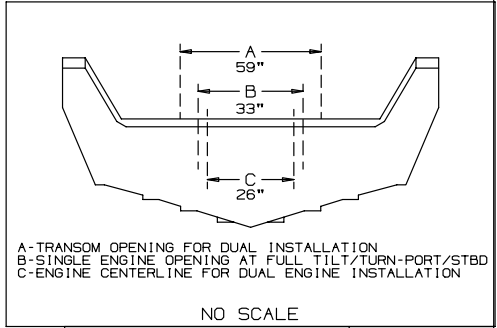

A-TRANSOM OPENING FOR DUAL INSTALLATION
B-SINGLE ENGINE OPENING AT FULL TILT/TURN-PORT/STBD
C-ENGINE CENTERLINE FOR DUAL ENGINE INSTALLATION

MERCURY MARINE	DR. BY BCK
DIV. OF BRUNSWICK CORP.	DATE 02-20-96
FOND DU LAC, WIS. 54935	SHT. OF

TITLE
MERCURY/MARINER
INSTALLATION DRAWING

SCALE 1:12	PART NO. 90-815258-17
---------------	--------------------------