

SONY

3-758-106-25 (1)

Multiscan Projector

VPH-1272Q/1272QM VPH-1252Q/1252QM

Installation Manual for Dealers

Before operating the unit, please read this manual thoroughly and retain it for future reference.

Mode d'emploi destiné aux revendeurs

Avant la mise en service de cet appareil, veuillez lire attentivement ce manuel que vous conserverez comme référence ultérieure.



VPH-1272Q/1272QM

VPH-1252Q/1252QM

SuperData EX / SuperData

© 1993 by Sony Corporation

Table of Contents

Installation

Projector dimensions	2
Using the handle and adjusters	4
Installation procedures	5
Installation diagrams	8
Modifications of parts	15
When installation does not comply with standard measurements	26
Notes on screen	31
Dynamic picture setting	34

Connections

Location and function of connectors	36
Connecting to the projector directly	37
Connecting when the projector is away from other equipment	40
Connecting more than four input sources	42

Adjustments

Before starting adjustment	46
Remote control operation	47
Adjustment displays and test patterns	52
Adjustment procedures	58
Lens focus adjustment	59
Registration adjustment	64
Fine adjustment of each input signal	88
Data reset	94
To activate the protection on the Remote Commander	97
Picture adjustment	98

Others

Changing the initialization time	100
List of the messages	101
List of washers used for non-standard installation	106
Projection distance by angle of optical axis	109

Installation

Contents		Page
Projector dimensions		2
Necessary clearance for maintenance		3
Using the handle and adjusters		4
How to use the adjusters		4
Installation procedures		5
Floor installation using front projection type screen		5
Ceiling installation using front projection type screen		6
Floor installation using rear projection type screen		7
Installation diagrams		8
Floor installation using front projection flat screen		8
Floor installation using front projection curved screen		9
Ceiling installation using front projection flat screen		10
Ceiling installation using front projection curved screen		11
When the screen size is not mentioned in the tables		12
Floor installation using rear projection flat screen		13
Modifications of parts		15
Opening the hood		15
Removing the power block and HV block		17
Changing the CRT spacers		18
Changing the lens spacers for front projection		20
Changing the lens spacers for rear projection		22
Changing the polarity		24
When installation does not comply with standard measurements		26
Variable range of the angle of optical axis in rear projection		26
Selecting the washer		27
How to insert the washers		30
Notes on screen		31
Screen size		31
Screens whose aspect ratio is not 3:4		31
Types of screen		32
Dynamic picture setting		34

Necessary Clearance for Maintenance

When you install the projector, be sure to provide the clearance around it as shown for maintenance service.

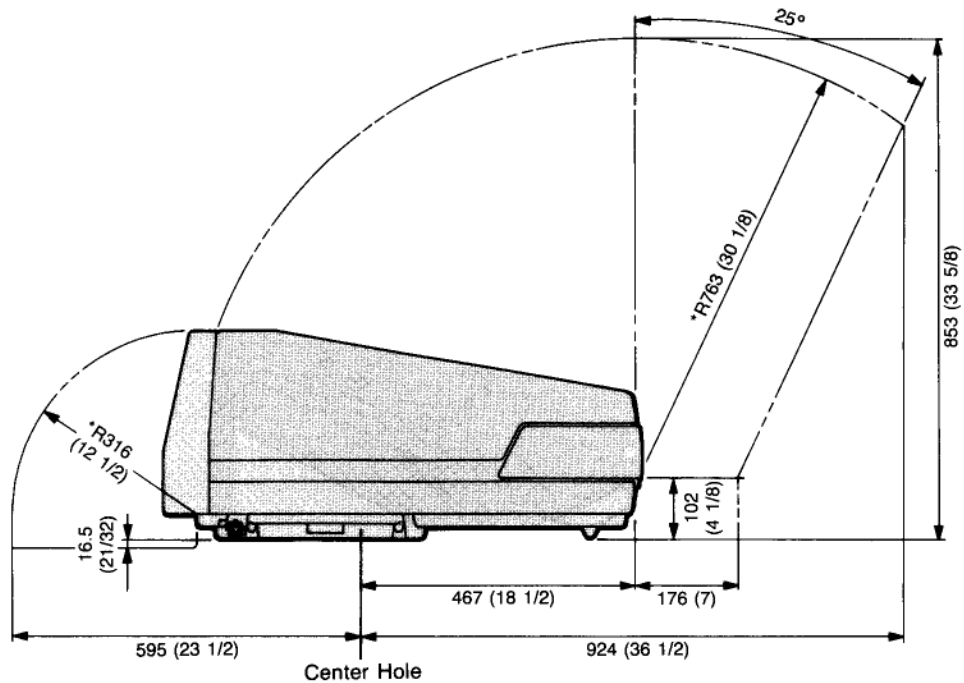

*R: Radius

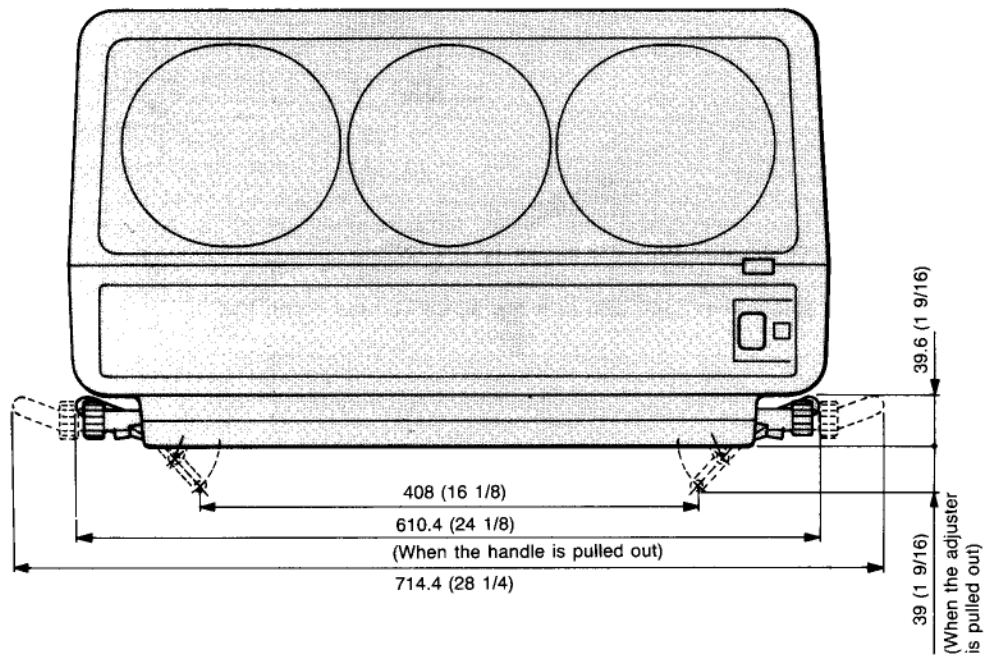

Unit: mm (inches)

Using the Handle and Adjusters

Handle

Used for carrying the projector. Pull out to use.

Putting away the handle

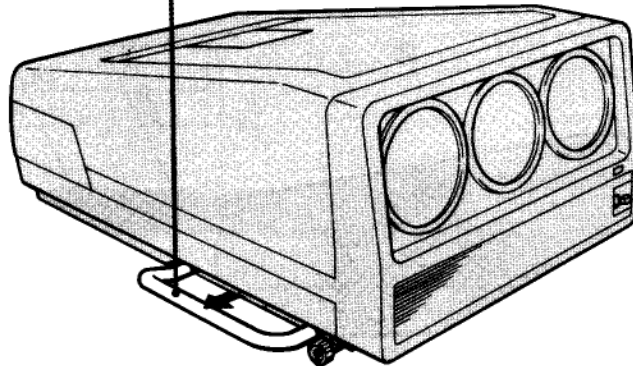
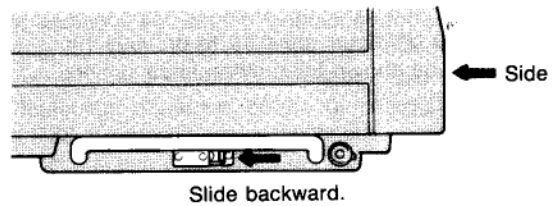

How to use the adjusters

The horizontal tilt of the projector can be adjusted using the adjusters.

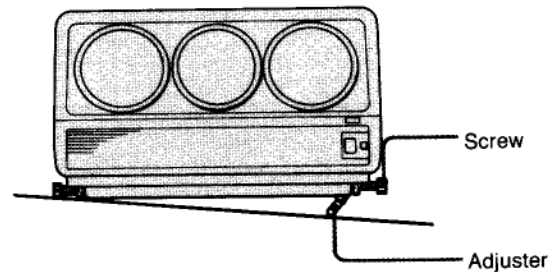

- 1 Lift the projector by its handle and turn the screw to the left.**
The adjuster comes out.
If you use a Philips-head screwdriver, you can turn the screw without lifting the projector.
 - 2 Adjust the height.**
If it is too high, turn the screw to the right to lower the projector. If it is too low, lift the projector again and turn the screw to the left to raise the projector.
- To retract the adjusters, tighten the screw by turning it to the right. Complete tightening of the screw puts away and locks the adjusters. Retract the adjusters when carrying the projector.

Installation Procedures

This projector is adjusted at the factory for projection on a 120-inch front projection type screen when the projector is installed on the floor/desk. If you install the projector in other conditions, modifications of some parts in the projector will be required. Therefore, installation procedures vary depending on the screen size, installation method and type of screen.

Floor Installation Using Front Projection Type Screen

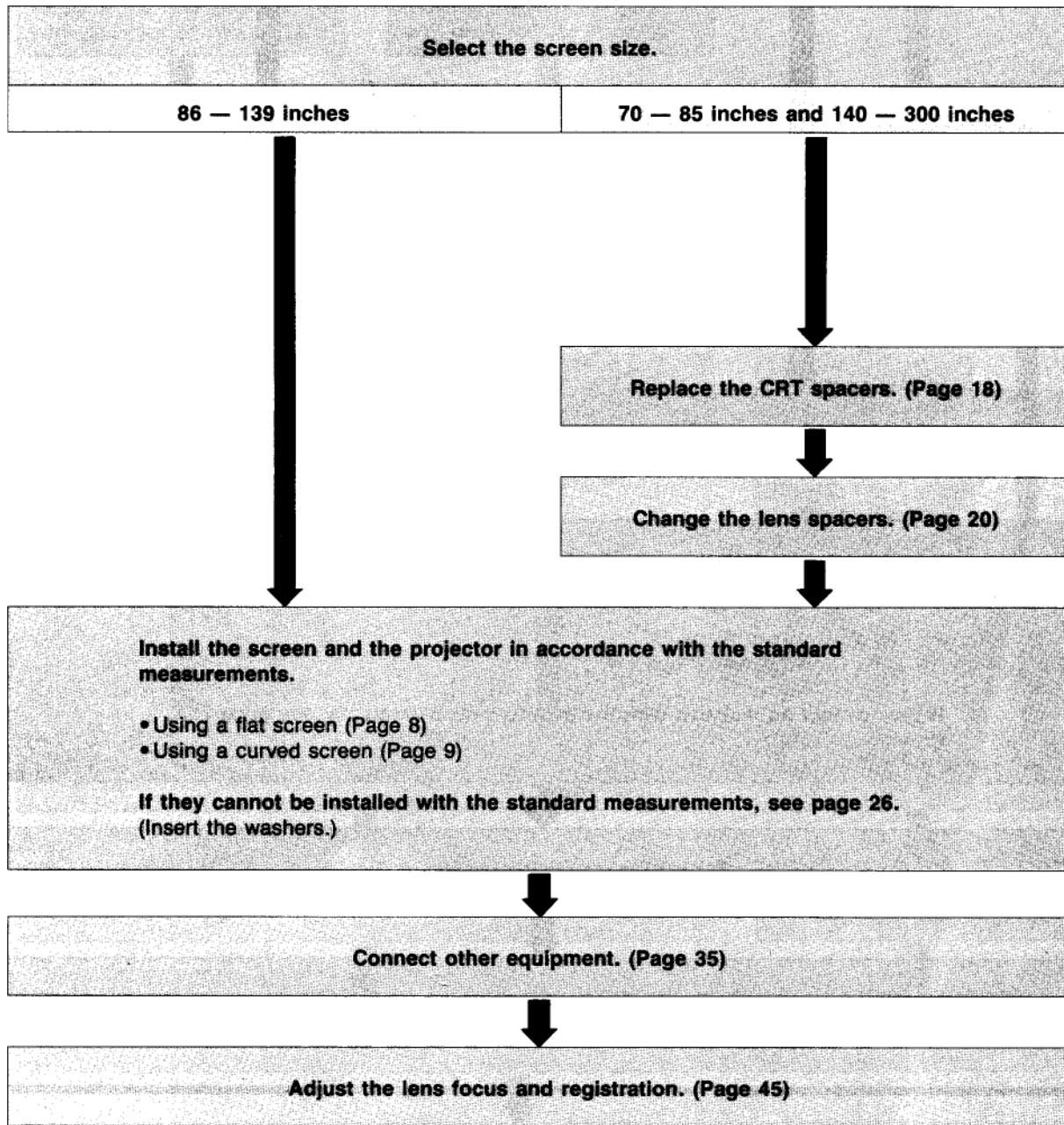

Ceiling Installation Using Front Projection Type Screen

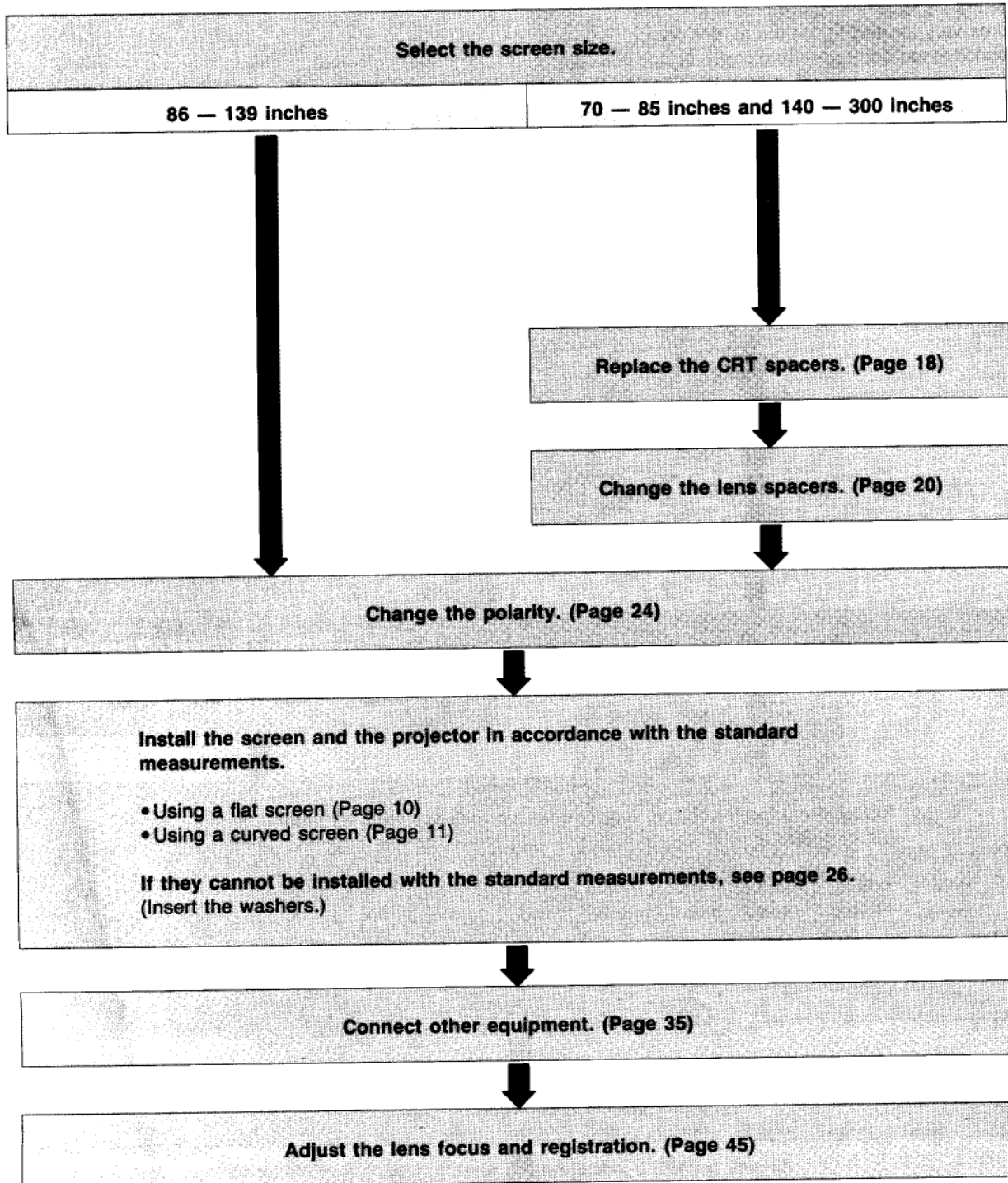

Floor Installation Using Rear Projection Type Screen

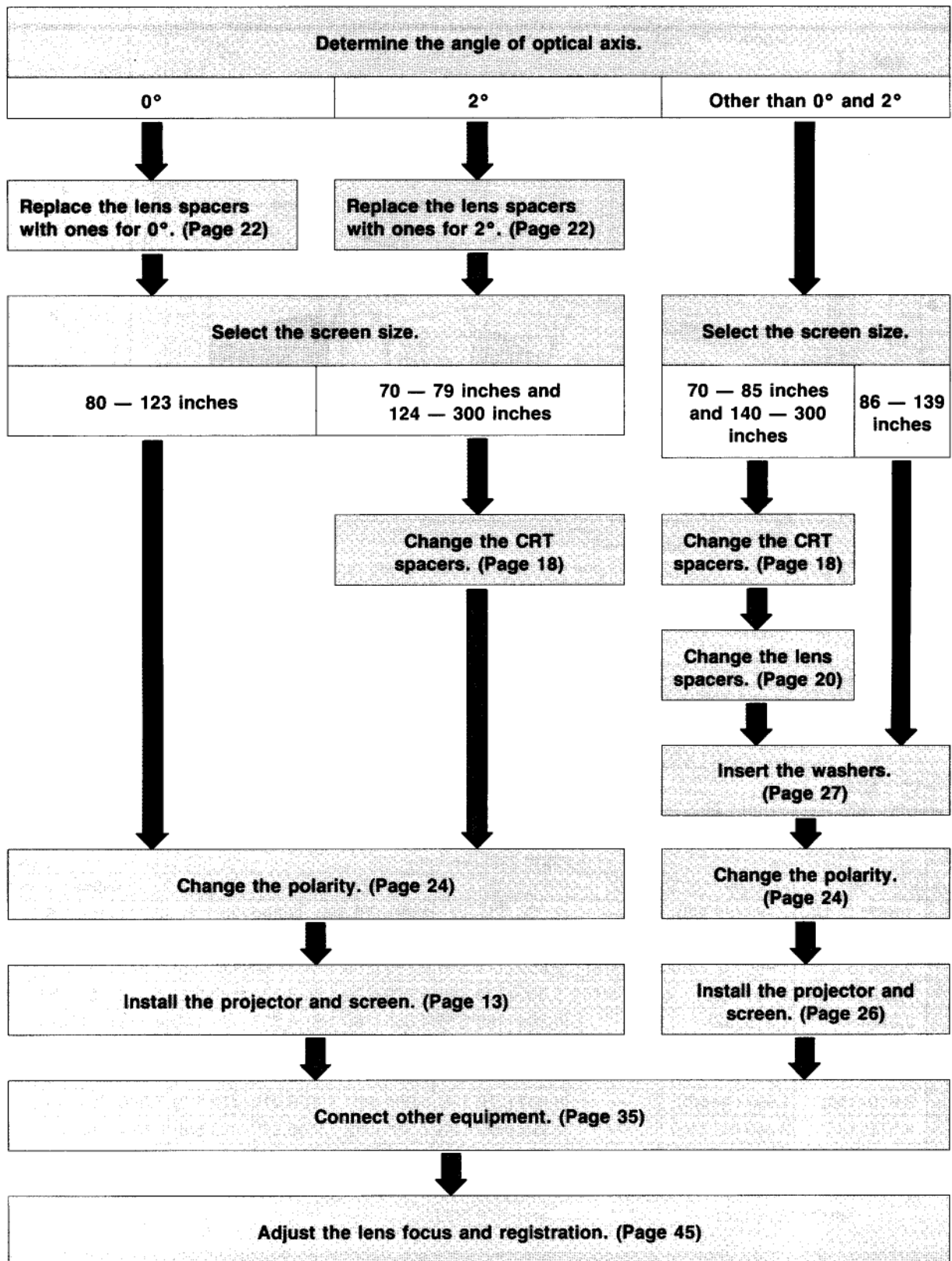

Installation Diagrams

Floor Installation Using Front Projection Flat Screen

Be sure that the projector is parallel to the floor.

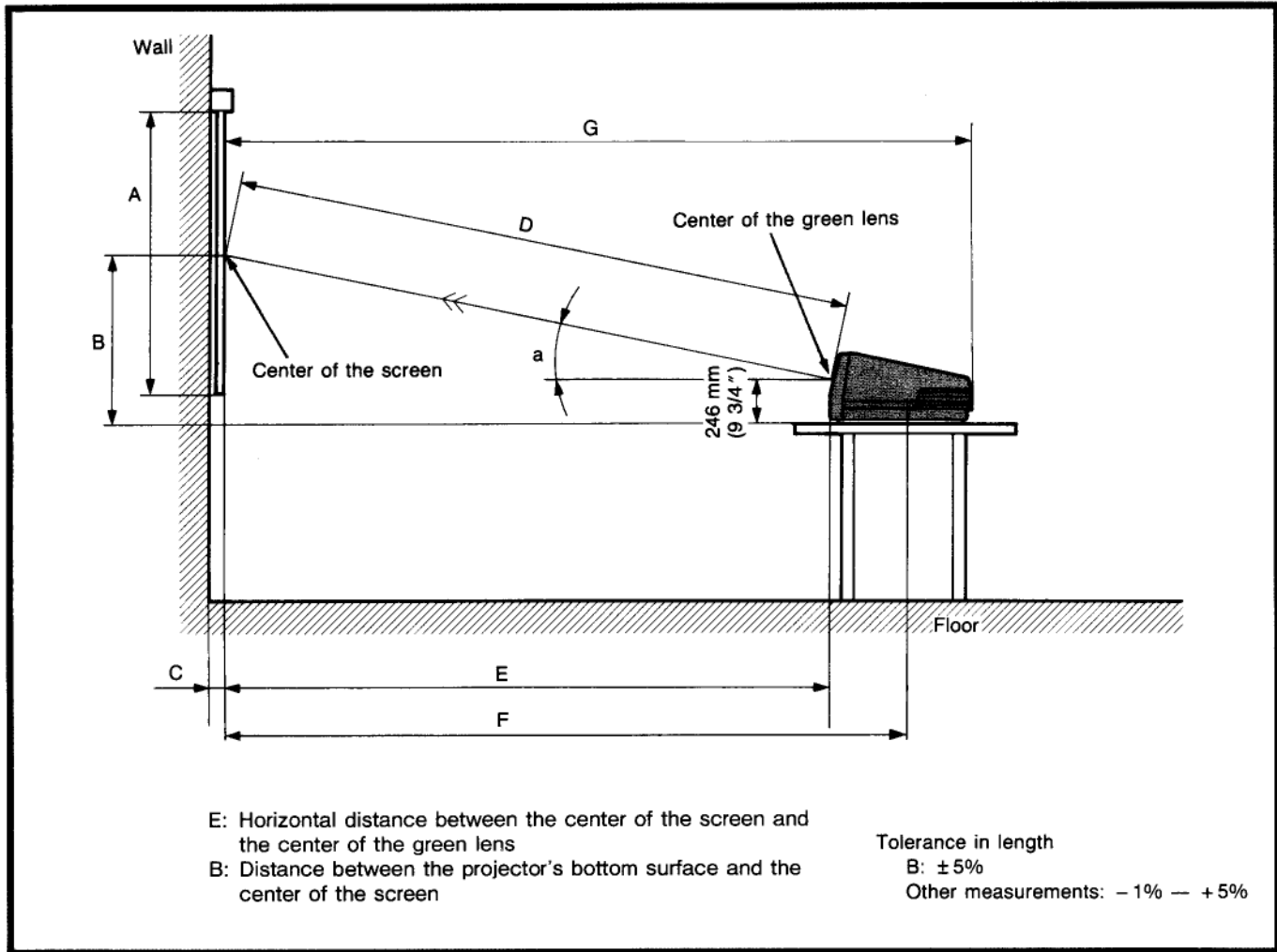

Screen size (Inches)	Length mm (Inches)							Angle (°)
	A	B	C	D	E	F	G	
70	1,067 (42 1/8)	743 (29 3/8)	—	2,056 (81)	1,995 (78 5/8)	2,292 (90 1/4)	2,771 (109 1/8)	14.0
80	1,219 (48)	808 (31 7/8)	—	2,326 (91 5/8)	2,257 (88 7/8)	2,553 (100 5/8)	3,030 (119 3/8)	14.0
100*	1,524 (60)	960 (37 7/8)	(28 (1 1/8))	2,859 (112 5/8)	2,769 (109 1/8)	3,062 (120 5/8)	3,540 (139 3/8)	14.5
120**	1,829 (72 1/8)	1,091 (43)	(32 (1 5/16))	3,386 (133 3/8)	3,279 (129 1/8)	3,570 (140 5/8)	4,048 (159 3/8)	14.5
150	2,286 (90)	1,319 (52)	—	4,204 (165 5/8)	4,065 (160 1/8)	4,353 (171 1/2)	4,832 (190 1/4)	14.8
180	2,743 (108)	1,517 (59 3/4)	—	4,981 (196 1/8)	4,816 (189 5/8)	5,102 (200 7/8)	5,581 (219 3/4)	14.8
200	3,048 (120)	1,653 (65 1/8)	—	5,516 (217 1/4)	5,334 (210)	5,619 (221 1/4)	6,097 (240 1/8)	14.8
250	3,810 (150)	1,997 (78 5/8)	—	6,862 (270 1/4)	6,635 (261 1/4)	6,919 (272 1/2)	7,396 (291 1/4)	14.8
300	4,572 (180)	2,343 (92 1/4)	—	8,208 (323 1/4)	7,935 (312 1/2)	8,218 (323 5/8)	8,694 (342 3/8)	14.8

* Sony VPS-100FH

** Sony VPS-120FH

Necessary modifications of parts

- Spacer change (not necessary for use of the 100- and 120-inch screens) (page 18)

Floor Installation Using Front Projection Curved Screen

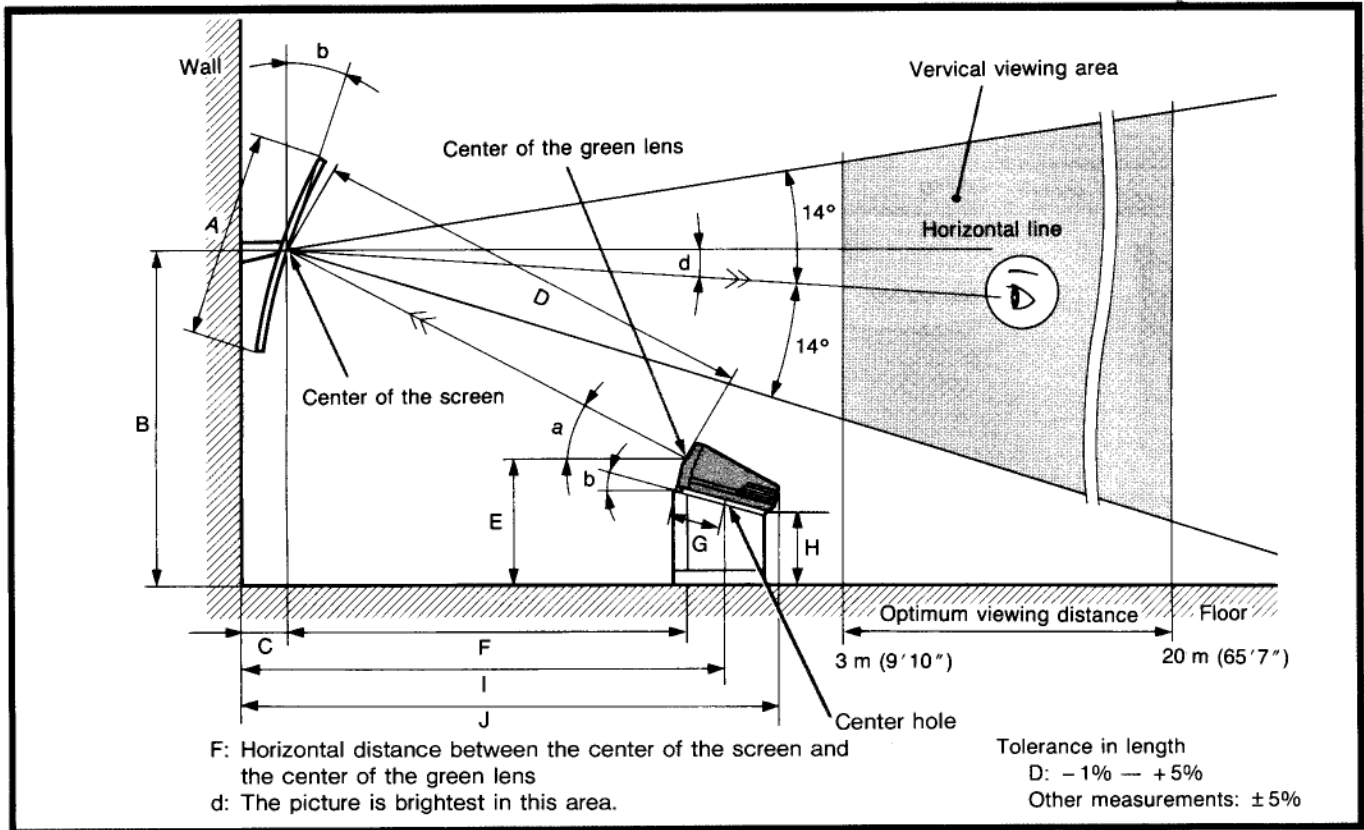

Screen size (inches)	Length mm (inches)										Angle (°)		
	A	B	C	D	E	F	G	H	I	J	a	b	d
72*	1,125 (44 3/8)	1,886 (74 3/8)	184 (7 1/4)	2,180 (85 7/8)	739 (29 1/8)	1,854 (73)	297 (11 3/4)	413 (16 3/8)	2,244 (88 3/8)	2,758 (108 5/8)	31.7	18.1	4.5
100**	1,600 (63)	2,107 (83)	303 (12)	3,002 (118 1/4)	545 (21 1/2)	2,564 (101)	293 (11 5/8)	223 (8 7/8)	3,073 (121)	3,585 (141 1/4)	31.4	17.4	3.4

*Sony VPS-72HG1 **Sony VPS-100HG1

Installation example

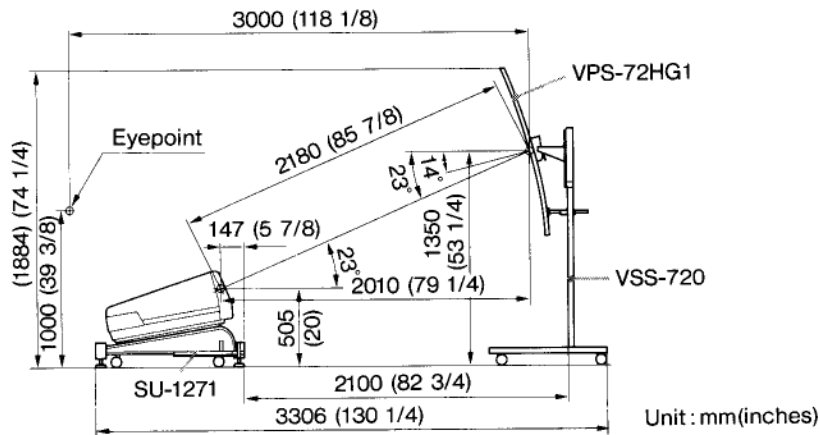

Necessary modifications of parts

- Spacer change (only for use of the 72-inch screen) (page 18)

Installation Diagrams

Ceiling Installation Using Front Projection Flat Screen

Be sure that the projector is parallel to the ceiling.

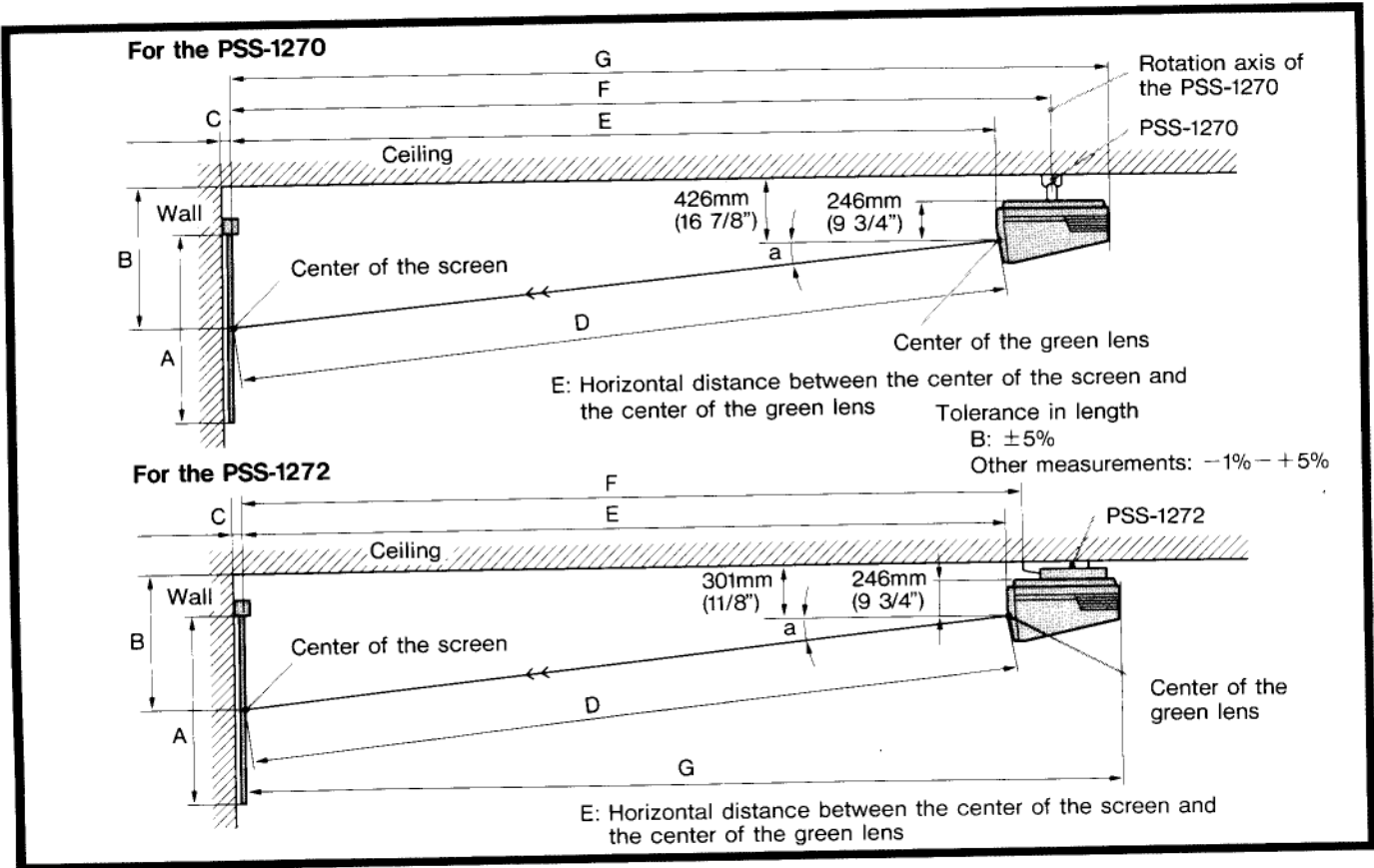

Screen size (inches)	For the PSS-1270								For the PSS-1272							
	Length mm (inches)							Angle (°)	Length mm (inches)							Angle (°)
	A	B	C	D	E	F	G		A	B	C	D	E	F	G	
70	1,067 (42 1/8)	923 (36 3/8)	—	2,056 (81)	1,995 (78 5/8)	2,318 (91 3/8)	2,771 (109 1/8)	14.0	1,067 (42 1/8)	798 (31 1/2)	—	2,056 (81)	1,995 (78 5/8)	2,148 (84 5/8)	2,771 (109 1/8)	14.0
80	1,219 (48)	988 (39)	—	2,326 (91 5/8)	2,257 (88 7/8)	2,577 (101 1/2)	3,030 (119 3/8)	14.0	1,219 (48)	863 (34)	—	2,326 (91 5/8)	2,257 (88 7/8)	2,407 (94 7/8)	3,030 (119 3/8)	14.0
100*	1,524 (60)	1,140 (45)	(28 (1 1/8))	2,859 (112 5/8)	2,769 (109 1/8)	3,087 (121 5/8)	3,540 (139 3/8)	14.5	1,524 (60)	1,015 (40)	(28 (1 1/8))	2,859 (112 5/8)	2,769 (109 1/8)	2,917 (114 7/8)	3,540 (139 3/8)	14.5
120**	1,829 (72 1/8)	1,271 (50 1/8)	(32 (1 5/16))	3,386 (133 3/8)	3,279 (129 1/8)	3,595 (141 5/8)	4,048 (159 3/8)	14.5	1,829 (72 1/8)	1,146 (45 1/8)	(32 (1 5/16))	3,386 (133 3/8)	3,279 (129 1/8)	3,425 (134 7/8)	4,048 (159 3/8)	14.5
150	2,286 (90)	1,499 (59 1/8)	—	4,204 (165 5/8)	4,065 (160 1/8)	4,379 (172 1/2)	4,832 (190 1/4)	14.8	2,286 (90)	1,374 (54 1/8)	—	4,204 (165 5/8)	4,065 (160 1/8)	4,209 (165 3/4)	4,832 (190 1/4)	14.8
180	2,743 (108)	1,697 (66 7/8)	—	4,981 (196 1/8)	4,816 (189 5/8)	5,128 (202)	5,581 (219 3/4)	14.8	2,743 (108)	1,572 (62)	—	4,981 (196 1/8)	4,816 (189 5/8)	4,958 (195 1/4)	5,581 (219 3/4)	14.8
200	3,048 (120)	1,833 (72 1/4)	—	5,516 (217 1/4)	5,334 (210)	5,644 (222 1/4)	6,097 (240 1/8)	14.8	3,048 (120)	1,708 (67 1/4)	—	5,516 (217 1/4)	5,334 (210)	5,474 (215 5/8)	6,097 (240 1/8)	14.8
250	3,810 (150)	2,177 (85 3/4)	—	6,862 (270 1/4)	6,635 (261 1/4)	6,943 (273 3/8)	7,396 (291 1/4)	14.8	3,810 (150)	2,052 (80 7/8)	—	6,862 (270 1/4)	6,635 (261 1/4)	6,773 (266 3/4)	7,396 (291 1/4)	14.8
300	4,572 (180)	2,523 (99 3/8)	—	8,208 (323 1/4)	7,935 (312 1/2)	8,241 (324 1/2)	8,694 (342 3/8)	14.8	4,572 (180)	2,398 (94 1/2)	—	8,208 (323 1/4)	7,935 (312 1/2)	8,071 (317 7/8)	8,694 (342 3/8)	14.8

*Sony VPS-100FH, **Sony VPS-120FH

Note "a" is the angle of the optical axis when the projector is in a horizontal position.
"A" is the effective vertical length of a 4:3 standard size screen.

Necessary modifications of parts

- Spacer change (not necessary for use of 100- and 120-inch screens) (page 18)
- Polarity change on the DC and E boards (page 24)

Ceiling Installation Using Front Projection Curved Screen

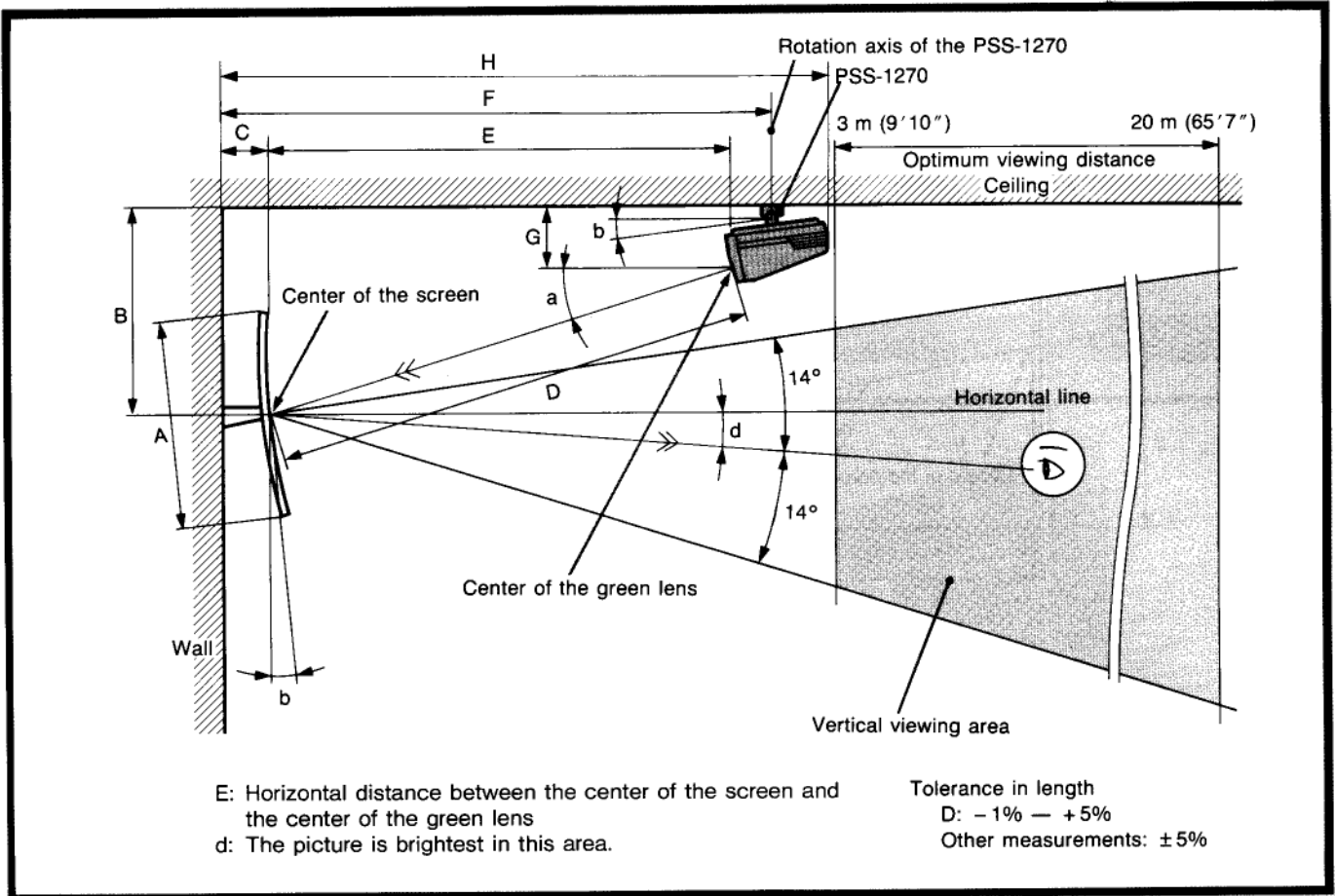

Screen size (Inches)	Length mm (inches)								Angle (°)		
	A	B	C	D	E	F	G	H	a	b	d
72*	1,125 (44 3/8)	1,271 (50 1/8)	185 (7 3/8)	2,180 (85 7/8)	2,025 (79 3/4)	2,477 (97 5/8)	464 (18 3/8)	2,965 (116 3/4)	21.7	8.1	5.5
100**	1,600 (63)	1,639 (64 5/8)	305 (12 1/8)	3,002 (118 1/4)	2,764 (108 7/8)	3,324 (130 7/8)	467 (18 1/2)	3,815 (150 1/4)	23.0	9.0	5.0

* Sony VPS-72HG1
 ** Sony VPS-100HG1

Necessary modifications of parts

- Spacer change (only for use of the 72-inch screen) (page 18)
- Polarity change on the DC and E boards (page 24)

Installation Diagrams

When the Screen Size is Not Mentioned in the Tables

When using the front projection screen for both floor and ceiling installations, the installation measurements can be calculated as follows:

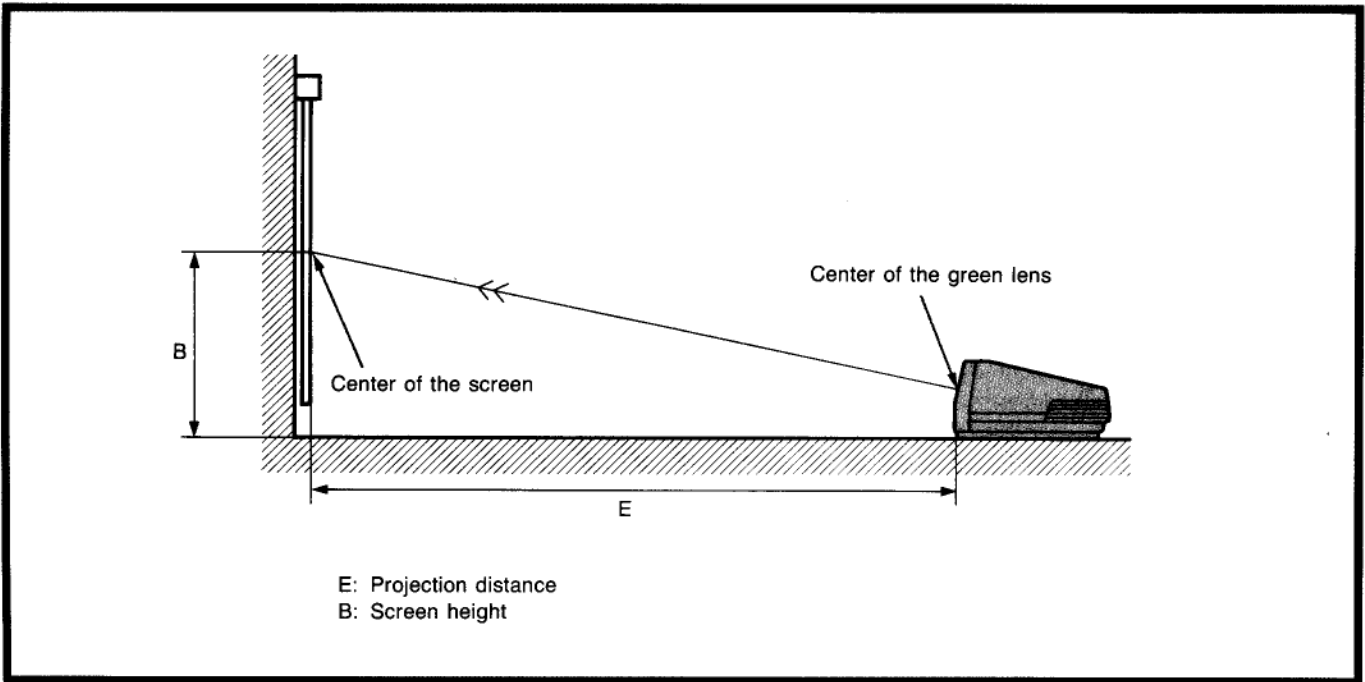

When the screen size is between 70 and 85 inches

$$E \text{ (mm)} = 25.78 \times \text{Screen size} + 191$$

$$B \text{ (mm)} = \text{Value E (mm)} \times 0.249 + 246$$

Example: 75-inch screen

$$E = 25.78 \times 75 + 191 = 2,125 \text{ mm}$$

$$B = 2,125 \times 0.249 + 246 = 775 \text{ mm}$$

When the screen size is between 86 and 139 inches

$$E \text{ (mm)} = 25.78 \times \text{Screen size} + 191$$

$$B \text{ (mm)} = \text{Value E (mm)} \times 0.258 + 246$$

When the screen size is between 140 and 300 inches

$$E \text{ (mm)} = 25.78 \times \text{Screen size} + 191$$

$$B \text{ (mm)} = \text{Value E (mm)} \times 0.264 + 246$$

Installation Diagrams

When the angle of optical axis is 2°

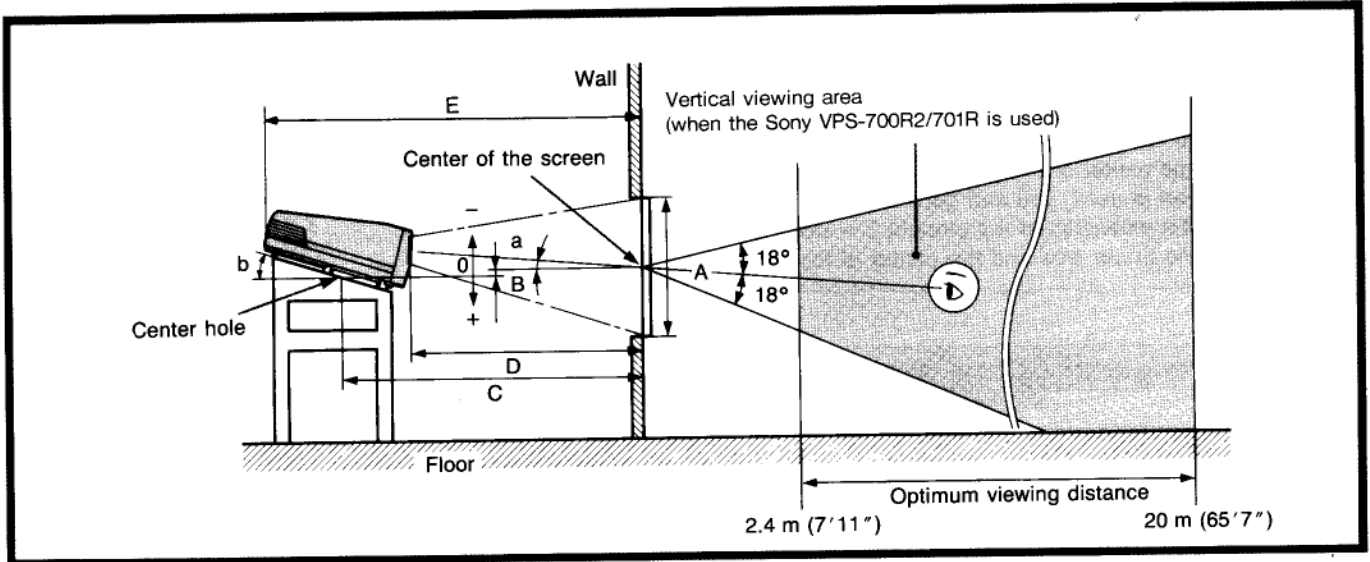

$a = 2^\circ$ ($b = 15.4^\circ \pm 0.5^\circ$)

Screen size (inches)	Length mm (inches)				
	A	B	C	D	E
70	1,067 (42 1/8)	91 (3 5/8)	2,388 (94 1/8)	2,035 (80 1/8)	2,821 (111 1/8)
80	1,219 (48)	80 (3 1/4)	2,685 (105 3/4)	2,334 (92)	3,118 (122 7/8)
100	1,524 (60)	63 (2 1/2)	3,174 (125)	2,826 (111 3/8)	3,607 (142 1/8)
120	1,829 (72 1/8)	45 (1 13/16)	3,692 (145 3/8)	3,347 (131 7/8)	4,125 (162 1/2)
150	2,286 (90)	17 (11/16)	4,496 (177 1/8)	4,153 (163 5/8)	4,929 (194 1/8)
180	2,743 (108)	-10 (-13/32)	5,266 (207 3/8)	4,924 (193 7/8)	5,699 (224 3/8)
200	3,048 (120)	-28 (-1 1/8)	5,791 (228)	5,450 (214 5/8)	6,224 (245 1/8)
250	3,810 (150)	-75 (-3)	7,118 (280 1/4)	6,779 (267)	7,551 (297 3/8)
300	4,572 (180)	-120 (-4 3/4)	8,447 (332 5/8)	8,109 (319 3/8)	8,880 (349 5/8)

Necessary modifications of parts

- Spacer change (not necessary for the CRT spacers when using the 100- and 120-inch screens) (page 18)
- Polarity change on the E board (page 24)

Modifications of Parts

To modify certain parts in the projector, such as changing the spacers, open the hood after removing the top panel. You may keep the hood open by supporting it with the stay, or remove the hood while making modifications. It is also necessary to remove the power block and HV block depending on the modifications.

Opening the Hood

- 1** Push the part marked "PUSH" on the control panel cover to open.
(Do not use force to open.)

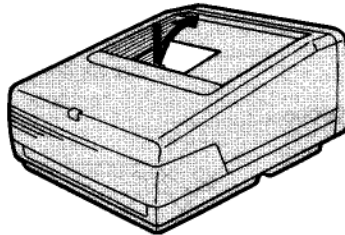

- 2** Loosen the two screws of the control panel and slide the top panel in the direction of the arrow. (The screws do not come out of the hole to prevent their getting lost.)

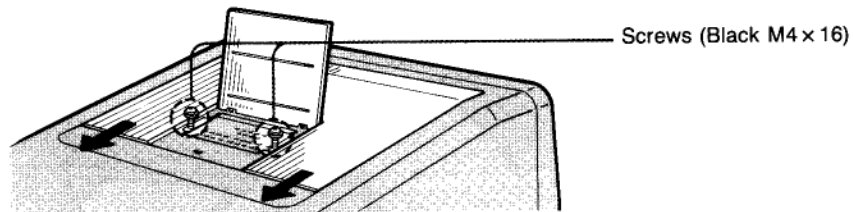

- 3** Open the top panel toward the lens section, and remove it.

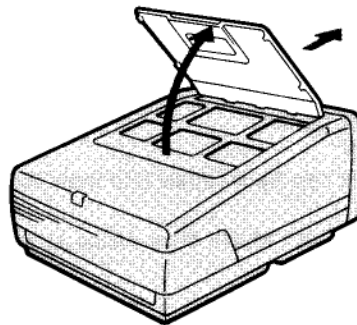

To be continued

Modifications of Parts

- 4** Press down the levers on both sides of the front panel to open toward you and remove the front panel.

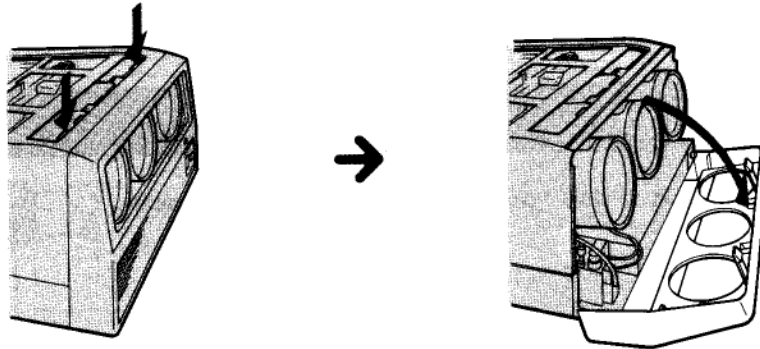

- 5** Lift the front side of the hood upward.

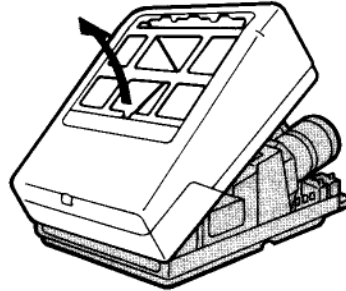

- 6** Raise the stay to support the hood properly.

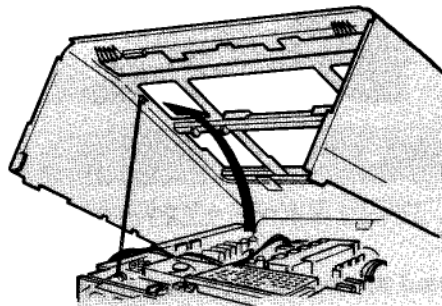

Note

You can remove the hood if necessary.

To replace the hood, front panel and top panel

- 1 Retract the stay properly in the stay lock.
- 2 Position the hood so that the two screws can be inserted into their locations on the control panel. Tighten the screws.
- 3 Replace the front panel and press it until both levers click. Make sure that the levers are properly fixed to the hood.
- 4 Replace the top panel.

Removing the Power Block and HV Block

Be sure to remove the power block first, and then remove the HV block.

- 1** Loosen the two screws at both sides of the power block.
 (The screws are retained in the hole, to prevent their getting lost.)

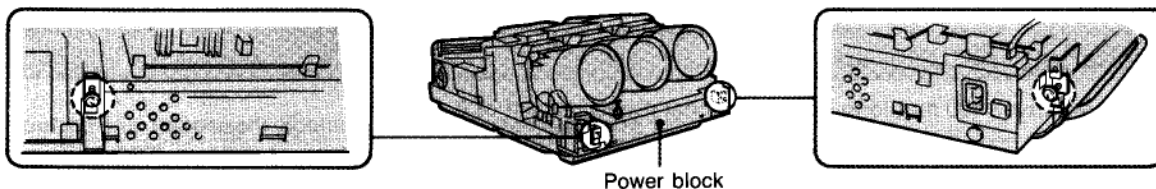

- 2** Unfasten the lock which secures the lead wires, and pull the power block out toward you.

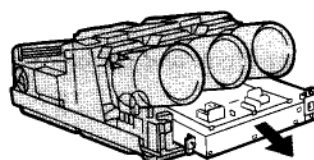

- 3** Loosen the two screws of the HV block. (The screws are retained in the hole, to prevent their getting lost.)

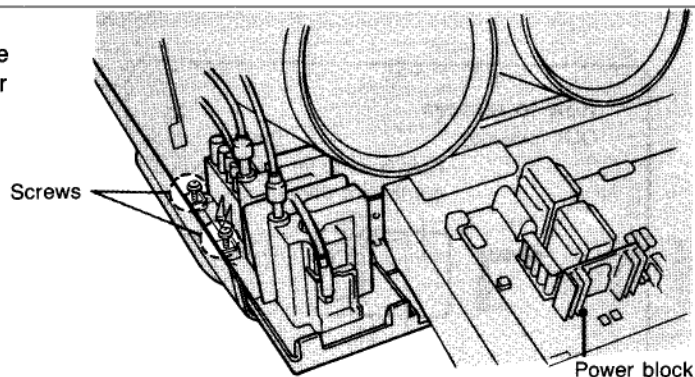

- 4** Pull the HV block out toward you.

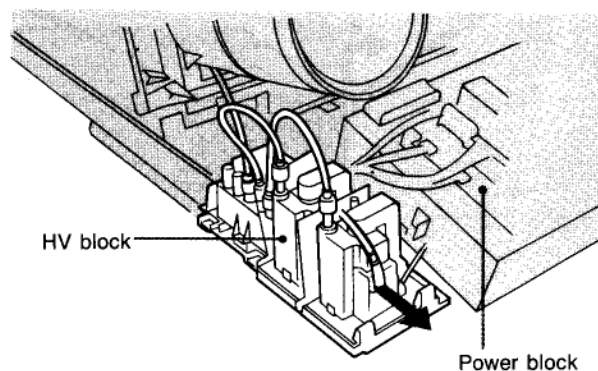

To replace the power block and HV block

- 1 Replace the HV block and tighten the two screws, making sure that the lead wire is not sagging.
- 2 Reinstall the power block. Make sure that it is pushed inside fully and then fasten the screws.

Be sure to replace the HV block first, then the power block.

Modifications of Parts

Changing the CRT Spacers

The CRT spacers of the projector attached at the factory are for 86- to 139-inch front projection (or for 80- to 123-inch rear projection). For projection other than these screen sizes, the CRT spacers must be replaced.

The CRT spacers should be attached to the blue and red cathode-ray tubes only.

How to change the CRT spacers

Use a box screwdriver 400 mm long with a diagonal measurement of 8 mm.

- 1** Remove the hood. (See page 15.)
- 2** Remove the power block and HV block. (See page 17.)
- 3** Loosen the four screws and remove the two CRT spacers that were attached at the factory for red and blue cathode-ray tubes.

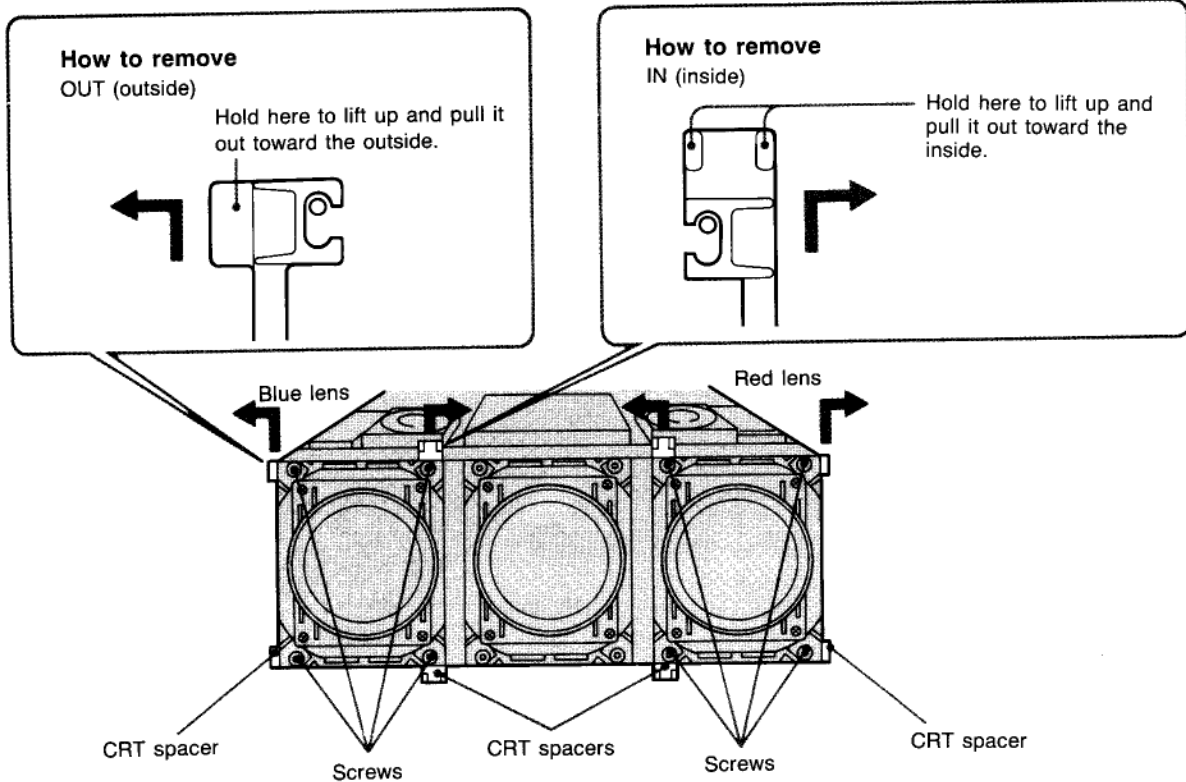

4 Confirm the necessary spacer size using the following table and attach the supplied CRT spacers to both the outside and inside of the red and blue cathode-ray tubes.

Attach the spacers with the "OUT" mark to the outside and the ones with the "IN" mark to the inside of the CRTs.

Front projection

Screen size (inches)	70 — 85	86 — 139	140 — 300
Size mark	S	M (preset at the factory)	L

Rear projection

Screen size (inches)	70 — 79	80 — 123	124 — 300
Size mark	S	M (preset at the factory)	L

Notes

- The screen size ranges at the front projection and rear projection are different.
- When the washers are to be inserted (page 26), see the table for front projection even in the case of rear projection.

CRT spacer

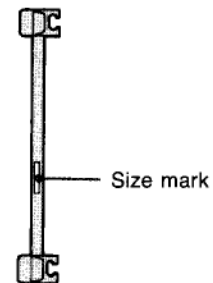

5 Fasten all screws as before.

Modifications of Parts

Changing the Lens Spacers for Front Projection

The lens spacers attached at the factory are for 86- to 139-inch front projection. For projection other than these screen sizes, change the lens spacers.

1 Remove the hood. (See page 15.)

2 Remove the power block and HV block. (See page 17.)

3 Loosen the four screws each of the red, green, and blue lenses. Make sure that the projections under the two upper screws are separated from the lens spacer.

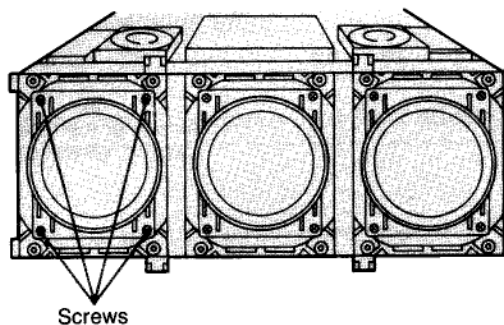

4 Separate the projection on the rear of the lens spacer from the hole mark on the lens support.

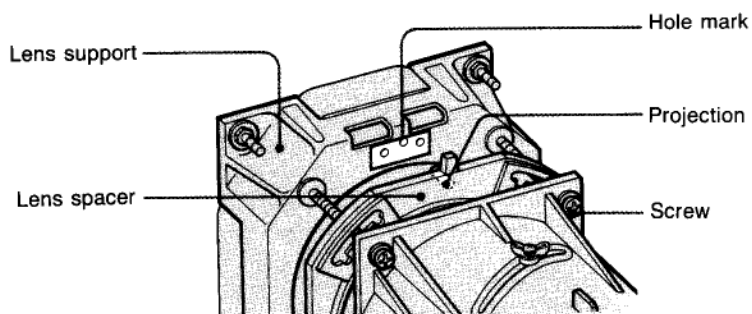

5 Confirm which hole is to be used, using the following table.
Align the screw with that hole to fix the lens spacer to the lens support.

Lens	Screen size (inches)	70 — 85	86 — 139	140 — 300
	Lens spacer			
Red	R FRONT	S	M (preset at the factory)	L
Green	G FRONT			
Blue	B FRONT			

③ Align the projection on the rear of the lens spacer with the hole mark on the lens support.

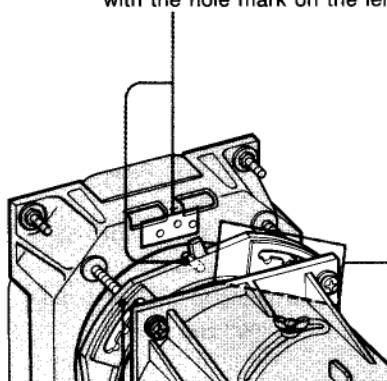

② Align the screw with the correct hole.

R FRONT : For red lens, front projection
G FRONT : For green lens, front projection
B FRONT : For blue lens, front projection

① Check the screen size.

6 Make sure that each lens spacer is firmly attached to the lens support and fasten the four screws for each lens.

7 Reinstall the HV block and power block. (See page 17.)

8 Reinstall the hood, front panel and top panel. (See page 16.)

Note

If it is difficult to change the lens spacer while the lens is attached, remove the lens.

Modifications of Parts

Changing the Lens Spacers for Rear Projection

Screen sizes and the necessary spacers

Determine the necessary spacers and confirm the size to be used.

Angle of optical axis	Lens	Lens spacer	Screen size*		
			70 — 79	80 — 123	124 — 300
0°	Red	R-0 REAR	S	M	L
	Green	G-0 REAR	Usable for all sizes		
	Blue	B-0 REAR	S	M	L
2°	Red	R-2 REAR	S	M	L
	Green	G-2 REAR			
	Blue	B-2 REAR			

* Note that the screen size ranges differ from those of lens spacers for front projection.

Note

When the washers are to be inserted, see the table for front projection (page 21), even in the case of rear projection.

How to change the lens spacers

- 1** Remove the hood. (See page 15.)
- 2** Remove the power block and HV block. (See page 17.)
- 3** Remove the lenses from the lens supports.
Remove the four screws of each lens and pull the lens out toward you.

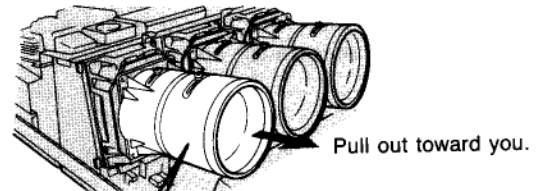
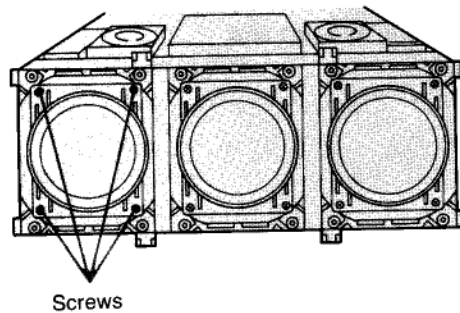

How to keep the separated lenses

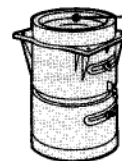

Be sure to keep the lenses with the CRT side up. Treat the lenses carefully.

4 Remove each lens spacer.

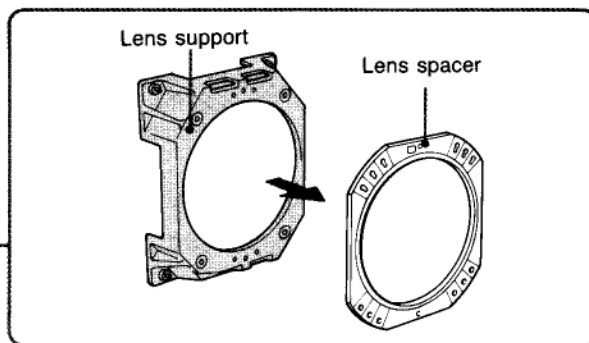
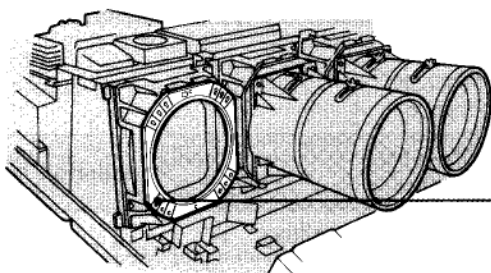

5 See the table on page 22 to select the correct lens spacer from the supplied ones. Then, confirm the hole to be used and fix the lens spacer with the lens support, aligning that hole.

- R-0 · REAR** : For red, angle of optical axis "0°"
- B-0 · REAR** : For blue, angle of optical axis "0°"
- R-2 · REAR** : For red, angle of optical axis "2°"
- B-2 · REAR** : For blue, angle of optical axis "2°"
- G-2 · REAR** : For green, angle of optical axis "2°"

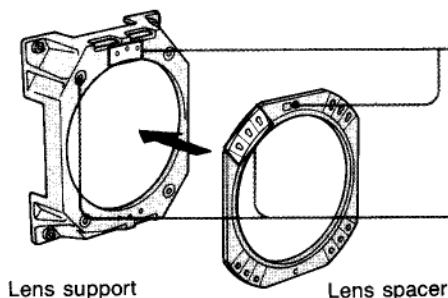
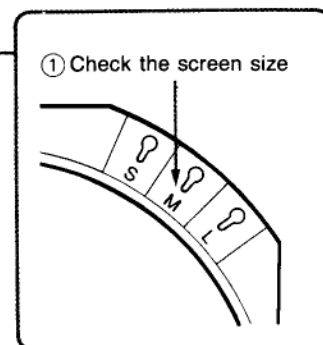
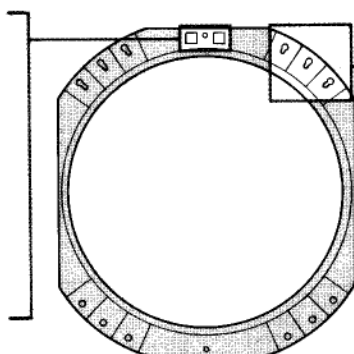

③ Align the projection on the rear of the lens spacer with the hole mark on the lens support.

② Align the hole to be used with the screw hole on the lens support.

6 Reinstall the lenses. Make sure that each lens spacer is firmly attached to the lens support, then fasten the four screws for each lens.

7 Reinstall the power block and HV block. (See page 17.)

8 Reinstall the hood, front panel and top panel. (See page 16.)

Modifications of Parts

Changing the Polarity

This projector is preset at the factory for use in front projection when the projector is installed on the floor/desk. When the projector is installed on the ceiling or used in rear projection, the display will be shown as follows when the power is turned on. Change the polarity to reverse the display.

A	<p>The letters are backward. Change the connectors on the E board.</p> <div data-bbox="318 646 716 932" style="border: 1px solid black; padding: 5px; text-align: center;"> <p>A-TUT-A</p> <p>For optimum performance, white screen will remain for 20min. For immediate use, push [PAGE] key.</p> </div>
B	<p>The letters are upside down. Change the connectors on the DC board.</p> <div data-bbox="318 1136 716 1421" style="border: 1px solid black; padding: 5px; text-align: center;"> <p>push [PAGE] key. For immediate use, remain for 20min. white screen will performance. For optimum</p> <p>A-TUT-A</p> </div>
C	<p>The letters are upside down and backward. Change the connectors on the DC and E boards.</p> <div data-bbox="318 1646 716 1932" style="border: 1px solid black; padding: 5px; text-align: center;"> <p>For optimum performance, white screen will remain for 20min. For immediate use, push [PAGE] key.</p> <p>A-TUT-A</p> </div>

Necessary polarity changes according to the installation methods

Installation methods	
Front projection, ceiling	
Rear projection, floor	
Rear projection, ceiling	
Rear projection using mirrors	<p data-bbox="894 772 1065 800">Using a mirror</p> <div data-bbox="1040 793 1490 1098"> </div> <p data-bbox="894 1146 1065 1173">Using a mirror</p> <div data-bbox="1040 1167 1490 1472"> </div> <p data-bbox="894 1520 1105 1547">Using two mirrors</p> <div data-bbox="1040 1541 1490 1845"> </div> <p data-bbox="865 1898 946 1925">Others</p>



Y: Necessary
N: Not necessary

	Change on DC board	Change on E board	On-screen Display
	Y	Y	C
	N	Y	A
	Y	N	B
	N	N	Correct picture
	Y	Y	C
	N	Y	A
Display the letters on the screen and determine which changes to be made.			

How to change the polarity

- 1 Turn off the power.
- 2 Open the hood. (See page 15.)
- 3 Change the connectors.

DC board: Shift the connectors to the immediately parallel receptacle.

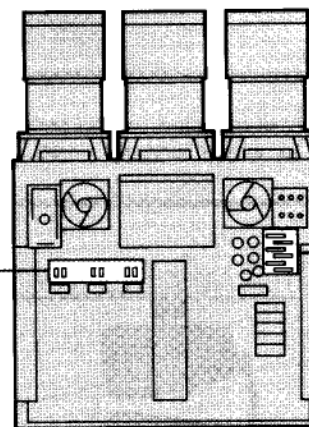
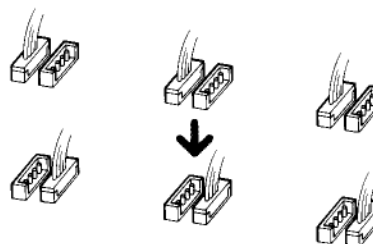

E board: Reinsert the connectors after turning them over (180°).

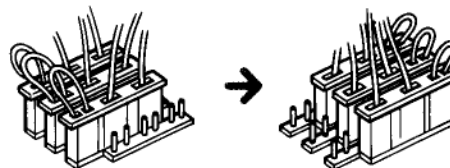

- 4 Make sure to insert the connectors firmly.

When Installation Does not Comply with Standard Measurements

If the projector cannot be installed using a standard installation method mentioned on pages 8 to 14, you cannot obtain the picture in focus no matter how you adjust the lens focus. In that case, insert the supplied washers between the lens and cathode-ray tube so that the lens can be focused.

Variable Range of the Angle of Optical Axis in Rear Projection

This projector can be installed on the floor within an angle of optical axis 2° to -13° as shown in the illustration.

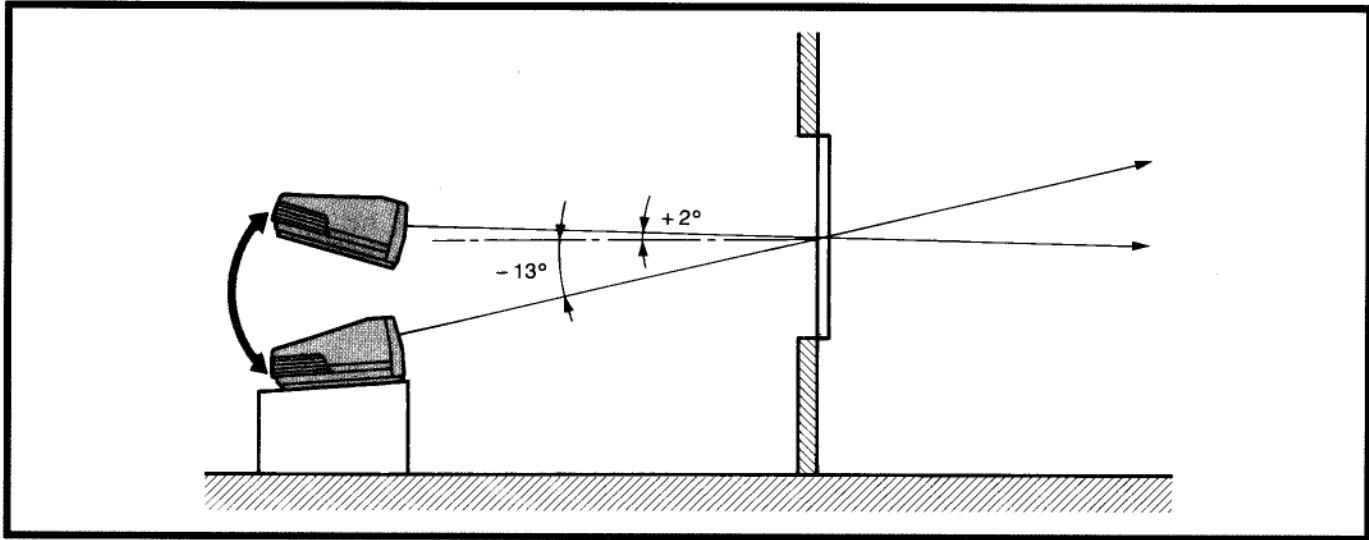

When the projector is installed on the ceiling, the angle of optical axis must be within $+3^\circ$ to $+13^\circ$.

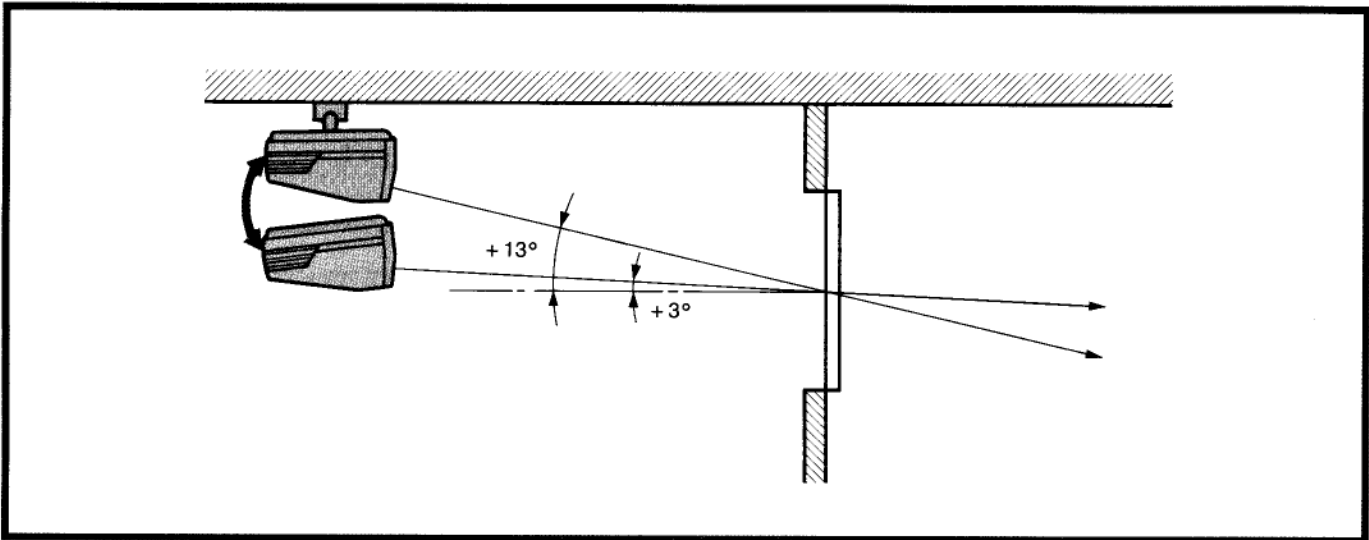

If the angle is 0° or 2° , you need not insert the washers.

Selecting the Washer

- Use the installation plan to find the angle (a) on the straight line from the center of the screen to the center of the projector's green lens. When there is an angle (b) on a screen (which is not perpendicular) as shown in the illustrations, subtract this angle (b) from the angle (a) to find the angle of optical axis against the screen.

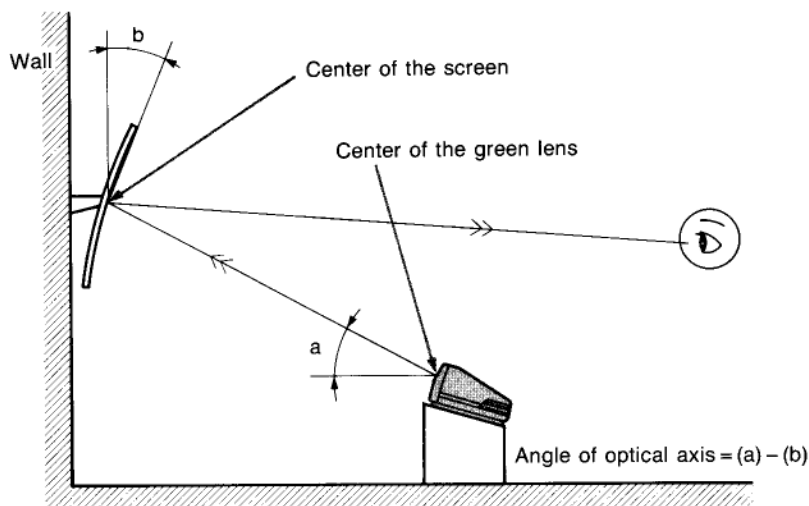
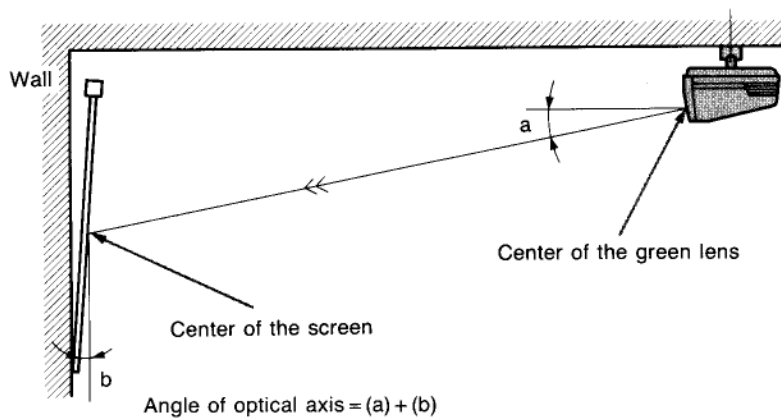
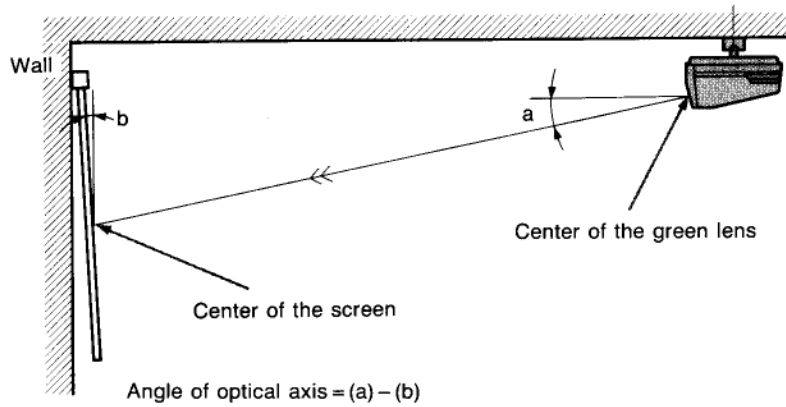

To be continued

When Installation Does not Comply with Standard Measurements

2 Use the “List of washers used for non-standard installation” to determine the washers (A) required in accordance with the corresponding angle and the screen size.

Example: When the angle is 8° with a 120-inch screen

The data given in the list is as follows.

A	0.4 + 0.4
B	65

(A: Washer thickness)
B: See page 67.)

In this case, install two 0.4-mm thick washers (supplied).

Notes

- Use the same washer for this angle in any installation method, including floor and ceiling installations. For example, use the same washer for 10° in both a floor installation with the angle of -10° and a ceiling installation with the angle of +10°.
- When you use a curved screen (or a screen with a large screen gain), determine the angle of the screen as first priority so that you can get the brightest picture. (Refer to the illustration with the curved screen in step 1 above.)
- If the angle of optical axis is changed, the projection distance also changes. Refer to the tables on pages 109 and 110 and remake your own installation plan by correcting the projection distance.

If you cannot get the optical axis using the installation plan, determine the washers to be used by the following procedure.

- 1** Measure the distance (E) from the screen to the center of the green lens.

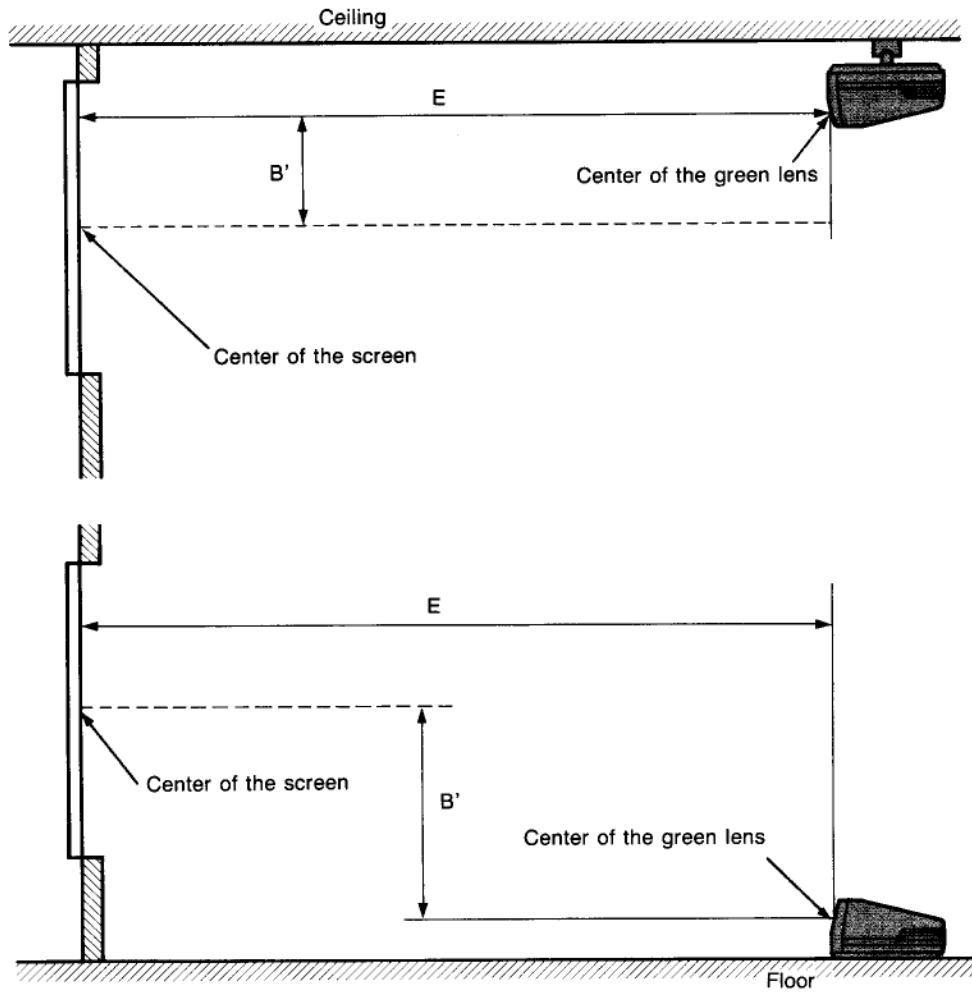

- 2** Measure the difference in height (B') between the center of the screen and the center of the green lens.

- 3** Divide B' by E.

- 4** Use the "List of washers used for non-standard installation" and determine the washers required in accordance with the corresponding value given by step 3 and the screen size.

When Installation does not Comply with Standard Measurement

How to insert the washers

1 Open the hood. (See page 15.)

2 Remove the power block and HV block. (See page 17.)

3 Remove the lenses from the lens supports.
Remove the four screws of each lens and pull the lens out toward you.

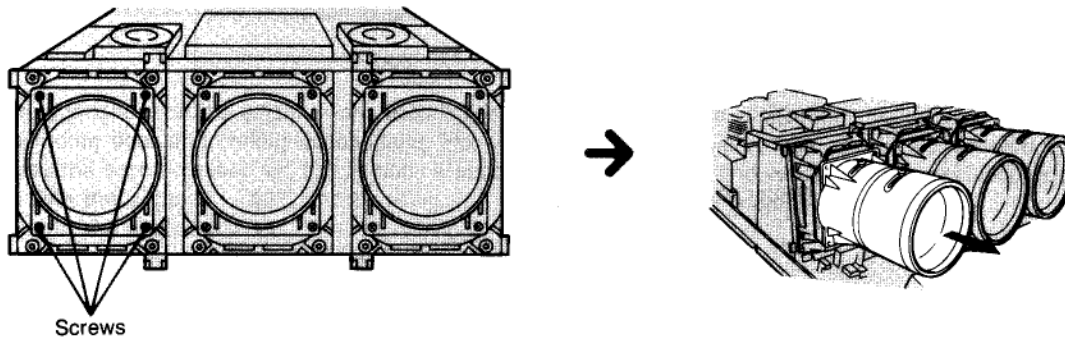

4 Mount the washers on the two screws attached at the bottom of the lens and reinstall the lenses, aligning them with the appropriate hole on the lens spacers.

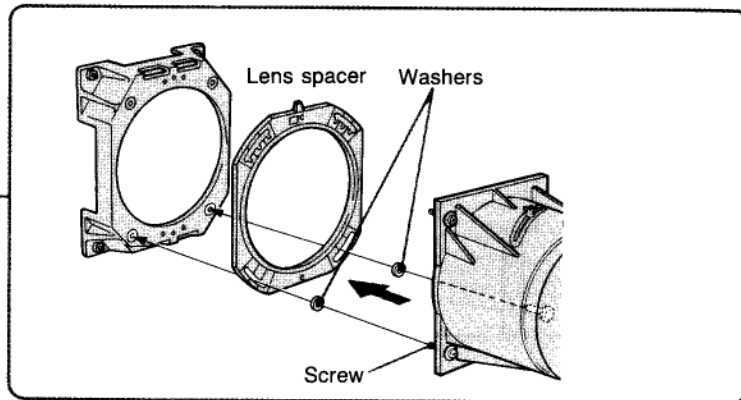
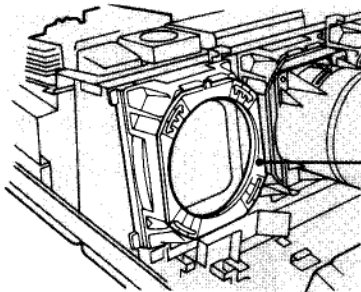

5 Fasten the four screws for each lens.

6 Reinstall the power block and HV block. (See page 17.)

7 Reinstall the hood and top panel. (See page 16.)

Notes

- Even if you install the projector using the rear projection, use the CRT spacers and lens spacers for front projection. (See pages 19 and 21.)

- Not to drop the washer inside the projector. If you do so, be sure to pick it up.

Screen Size

The screen size defines the size of a screen using the diagonal length in inches while the aspect ratio of the screen is 4:3. The ratio of the screen height, width, and diagonal is 3:4:5. If you use a screen whose size is not given in the table, you can calculate the screen height and width from the screen size (inches) as follows.

$$\text{Height (mm)} = \text{Screen size} \times 25.4 \times 3/5$$

$$\text{Width (mm)} = \text{Screen size} \times 25.4 \times 4/5$$

Screen size and dimensions

Screen size (inches) (Diagonal)	Height (mm)	Width (mm)
70	1067	1422
72	1097	1463
80	1219	1626
100	1524	2032
120	1829	2438
150	2286	3048
180	2743	3058
200	3048	4064
250	3810	5080
300	4572	6096

Screens Whose Aspect Ratio Is Not 3:4

When the height is greater

Calculate the approximate screen size from the screen height as shown below. Install the projector and screen in accordance with the screen size obtained.

--- : Screen whose aspect ratio is 3:4

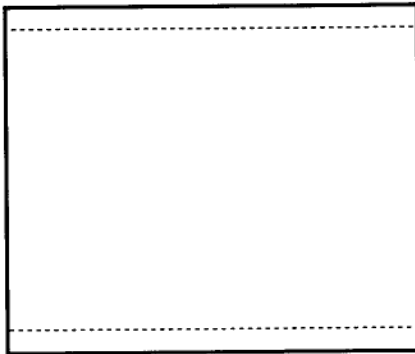

$$\text{Screen size} = \text{Height (mm)} \times 5/3 \div 25.4$$

Example: When the screen height is 1500 mm
 $1500 \times 5/3 \div 25.4 = 98$ inches

When the width is greater

Calculate the approximate screen size from the screen width as shown below. Install the projector and screen in accordance with the screen size obtained.

--- : Screen whose aspect ratio is 3:4

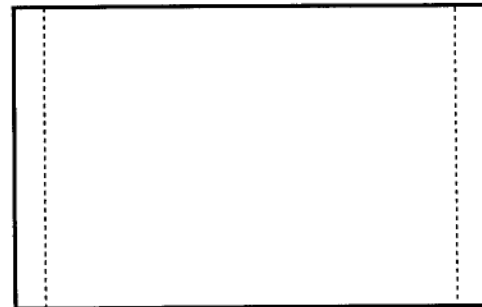

$$\text{Screen size} = \text{Width (mm)} \times 5/4 \div 25.4$$

Example: When the screen width is 2000 mm
 $2000 \times 5/4 \div 25.4 = 98$ inches

Types of Screen

Front projection screen for floor installation

The bead screen is recommended. A screen of this type reflects the brightest light to the incidence position. The following Sony screens are bead screens: VPS-80FH/100FH/120FH (manual screen)

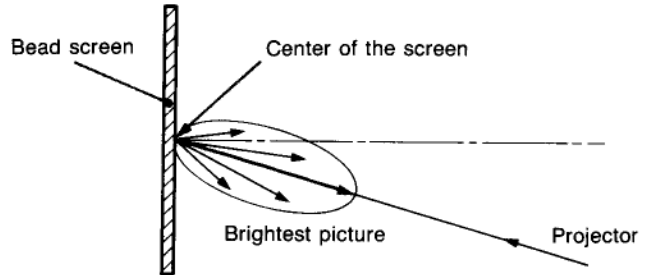

Front projection screen for ceiling installation

The silver screen is recommended. You can get a picture that is two to four times brighter.

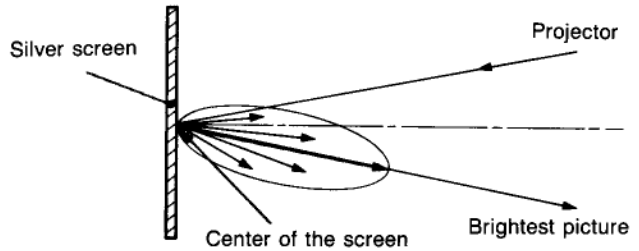

Rear projection screen

A screen manufactured using two sheets, the fresnel and lenticular, is recommended for a bright and clear full-screen picture projection. The Sony VPS-700R, VPS-700R2 and VPS-701R rear screens are this type with black stripes that can produce high quality contrast by blocking out outside light.

The illustration shows the horizontal viewing area for a screen of this type.

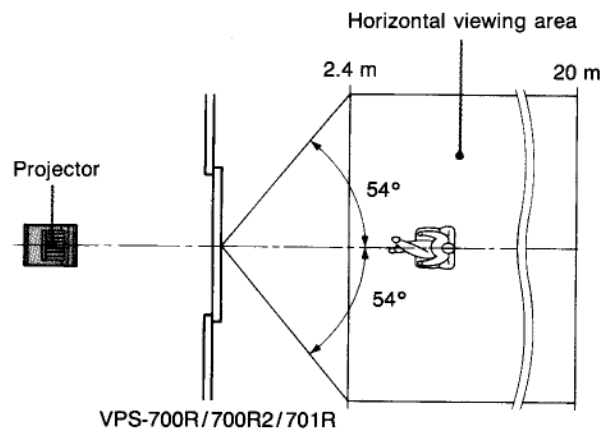

Aluminum (Curved) screen

When you install the projector in a narrow room, you can get a brighter picture using the aluminum screen for both floor and ceiling installations. An aluminum screen has a narrow directivity, resulting in a limited viewing area. However, it allows you to get a very bright picture in a narrow room. Note that a screen of this type can easily be affected by outside light and therefore requires consideration for a proper lighting system arrangement in the room. The Sony VPS-72HG1 and VPS-100HG1 screens are aluminum screens.

The illustrations below show the horizontal viewing area for a screen of this type.

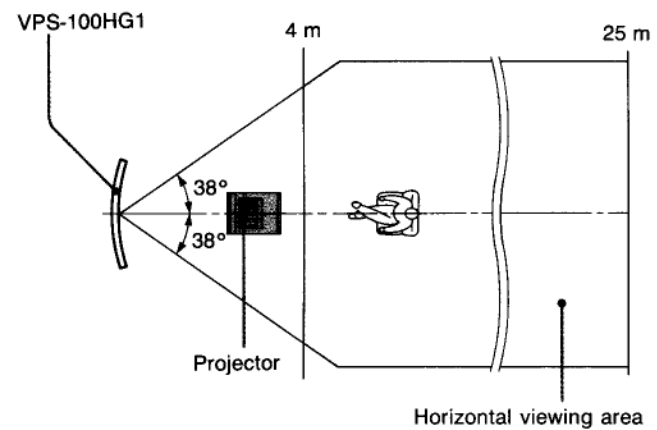
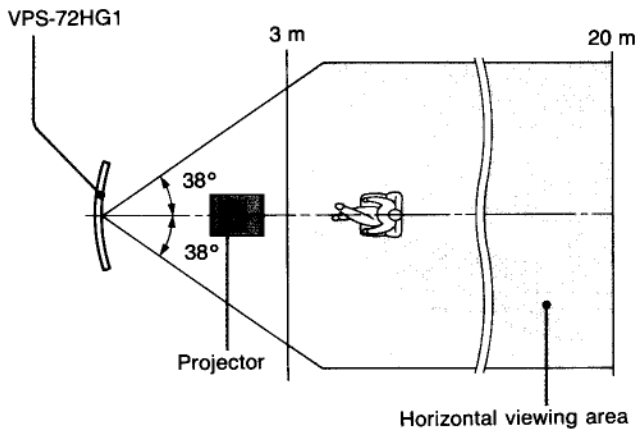
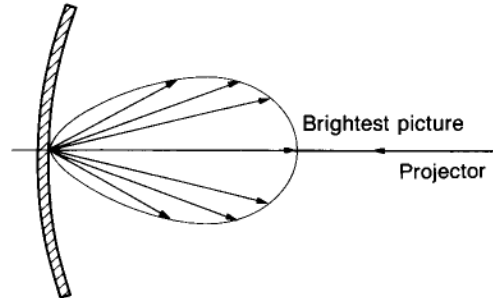

White screen

When a number of viewers watch picture projection in a wide area, a picture that appears equally bright from all parts of the room can be obtained using the white screen for both floor and ceiling installations. Note that you will not be able to get a clear picture in this case unless the room is dark.

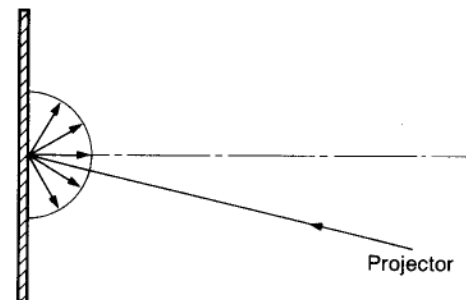

Dynamic Picture Setting

When the video signal is input, you can obtain the picture of high quality contrast by switching the DYNAMIC PIC SW on the BA board. (The switch is set to OFF at the factory.)

1 Remove the hood. (See page 15.)

2 Remove the three screws on the upper part of the connector panel frame to remove.

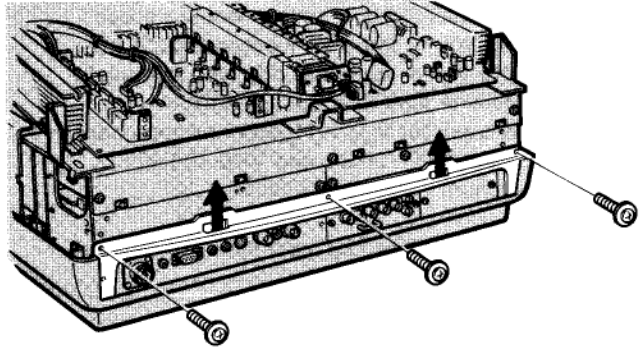

3 Remove the two screws on the upper cover of the connector panel and remove the cover.

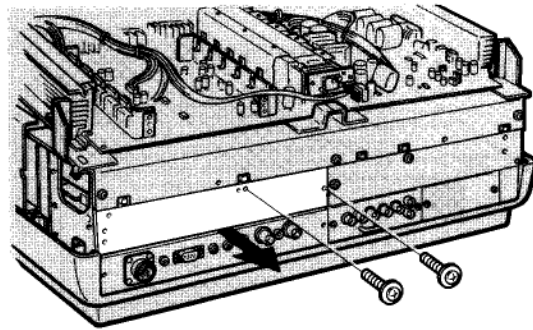

4 Pull the BA board out toward you and set the SW1: DYNAMIC PIC SW on the board to ON.

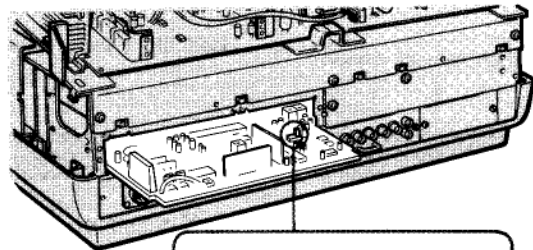

SW1: DYNAMIC PIC SW

ON

5 Replace the parts following steps 4 to 1 in reverse.